

UPPER MILFORD TOWNSHIP  
LEHIGH COUNTY  
P.O. Box 210, Old Zionsville, PA 18068 Phone (610) 966-3223

**DRIVEWAY PERMIT APPLICATION**

DRIVE AND/OR ACCESS PERMIT NO. \_\_\_\_\_ DATE \_\_\_\_\_ FEE \$45.00

THIS CERTIFIES THAT

\_\_\_\_\_  
NAME OF BUILDER PHONE NO.

\_\_\_\_\_  
NAME OF PROPERTY OWNER

\_\_\_\_\_  
SIGNATURE OF PROPERTY OWNER

\_\_\_\_\_  
ADDRESS OF PROPERTY OWNER

Has applied for permission to construct a driveway or \_\_\_\_\_

at \_\_\_\_\_  
LOCATION OF DRIVEWAY

Application for such permit shall be made by the owner or occupier, or by his contractor or agent, in writing, on forms provided by the township and in accordance with such rules and regulations as may be established by the township. There shall be appended to each application a drawing or plan showing the outlines of the property affected with existing improvements thereon, existing drains, culverts, footwalks, drives or driveways, with the proposed drain, culvert, footwalk, drive or driveway, proposed to be added, and the relationship of the foregoing to the township road, particularly with relationship to the effect on the drainage of said road. The application shall also state the type of material to be used on the driveway.

The Applicant named above has been granted permission to construct a driveway at the location stated, subject to the terms of the Upper Milford Township Ordinance No. 42 relating thereto and conditions imposed by the Board of Supervisors of Upper Milford Township, and the attachment hereto.

Approved by \_\_\_\_\_

Title \_\_\_\_\_

Date \_\_\_\_\_

\_\_\_\_\_  
Township Official

Attachment- Specific Driveway Details pertaining to your installation.

Purpose and Application

It is in the public interest to regulate the location, design, construction, maintenance, and drainage of access driveways and other property within township right-of-way for the purpose of security, economy of maintenance, preservation of proper drainage and safe and reasonable access.

The applicant agrees to perform all work in careful manner and in accordance with the issued permit. The applicant agrees to save and hold harmless and indemnify Upper Milford Township, its officers, agents and employees from any and all claims for damage asserted by anyone as a result of injury to person or property, loss or damage resulting from or in any way related to the issuance of this permit.

All driveways shall be constructed so as not to impair drainage within the right-of-way, alter stability of improved area, or change the drainage or adjacent areas.

Where a drainage ditch or swale exists, the permittee shall install adequate pipe under the driveway, or maintain the swale, in accordance with driveway details on the driveway permit application.

If during installation of the driveway the pavement or shoulders are damaged, the permittee shall restore pavement or shoulders to their former condition, at the expense of the permittee.

1. Stone drives shall consist of 4" depth crushed stone, paved drives shall consist of 2" depth bituminous wearing course, ID-2 on 4" depth crushed stone.
2. All drives using a swale shall be paved for a minimum distance of 15' from the edge of pavement. All drives with a slope in excess of 6% shall be paved for a minimum distance of 50' from the edge of pavement.
3. Visibility from the drive location should range from approximately 150' for roadway speeds of 23 mph to approximately 350' for speeds of 45 mph.

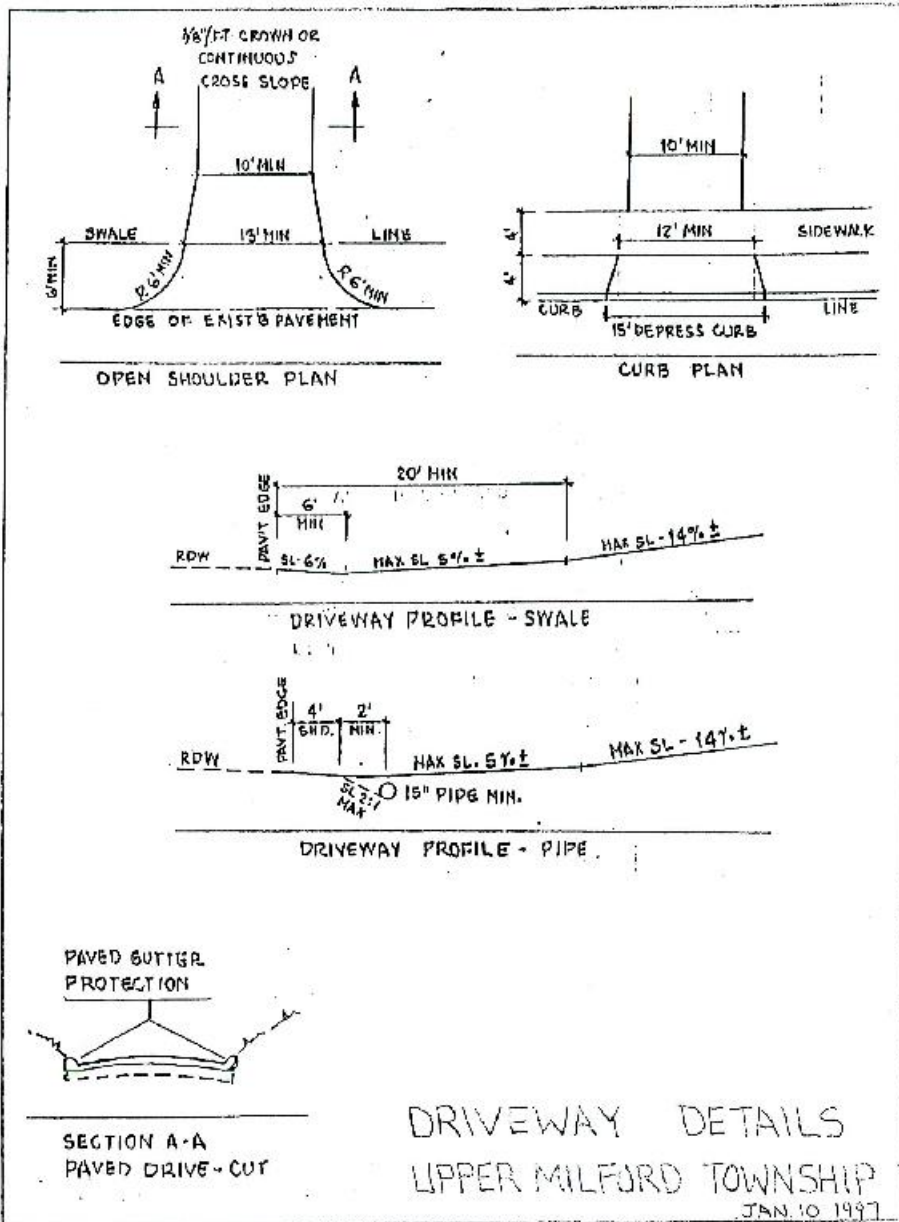

**UPPER MILFORD TOWNSHIP  
LEHIGH COUNTY**  
5671 Chestnut Street  
P.O. Box 210 Old Zionsville, PA 18068  
Phone: 610-966-3223 Fax: 610-966-5184

**DRIVEWAY PERMIT ADDENDUM**

**CURB CUT AND/OR CURB REPLACEMENT REQUIREMENTS**

1. If concrete curb is provided along the street where a driveway access is proposed and a depressed curb cut is not provided at the access location, one must be provided and constructed according to Township Specifications.
2. Construction and installation of a depressed curb, conversion of a depressed curb to a plain curb or any similar curb construction shall be inspected and approved by the Zoning Officer. (Existing depressed curbs that are not used must be restored to a straight plain curb)
3. You shall contact the Zoning Officer to determine what inspections will be required.
4. You must notify the Zoning Officer 24 hours in advance of desired inspections. (Provide street address, subdivision, owners name)
5. Work performed beyond the point indicated for each inspection may be required to be redone so it can be inspected.
6. Certificate of Occupancy permits will be withheld until all aspects of the driveway permit are satisfactorily completed to Township standards and all inspections are approved.
7. Payment of inspection fees is the responsibility of landowner.

Contact: Alan Brokate  
Zoning Officer / Building Official  
5671 Chestnut Street  
P.O. Box 210  
Old Zionsville, PA 18068  
Phone: 610-966-3223  
Fax: 610-966-5184

See page 1, 2, 3 for the construction details for concrete curb construction.

1

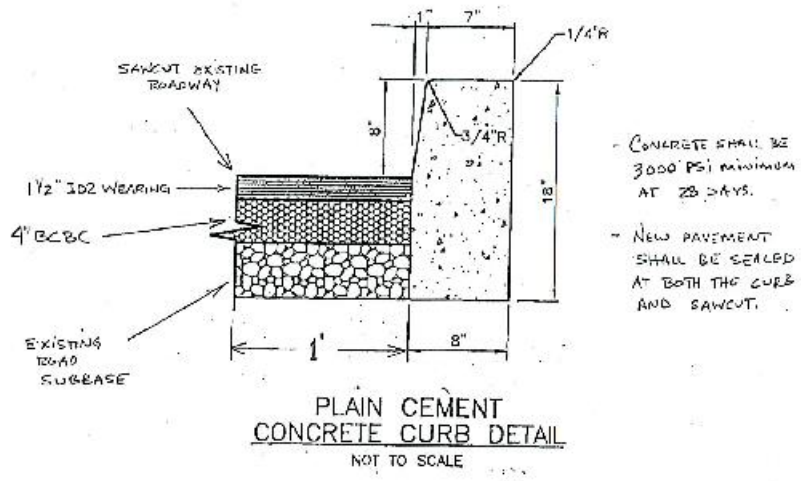

**SCHOOR DEPALMA**  
Engineers and Consultants

1555 BUSTARD ROAD, SUITE 50T  
P.O. BOX 304  
KULPSVILLE, PA 19443  
TEL (215)361-6050  
FAX (215)361-6160

MANALAPAN • ARMONK • ATLANTIC CITY • BRICK • CLINTON • EXTON • KULPSVILLE  
PARSIPPANY • PHILADELPHIA • PHILLIPSBURG • STAFFORD • VOORHEES

2

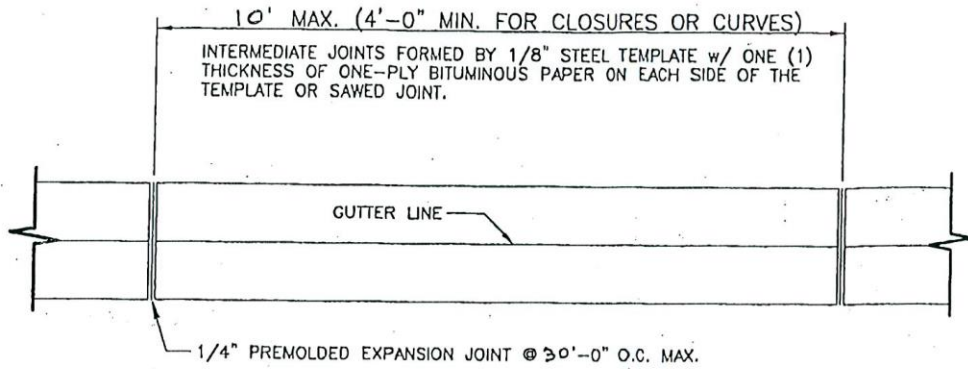

NORMAL CURB GUTTER

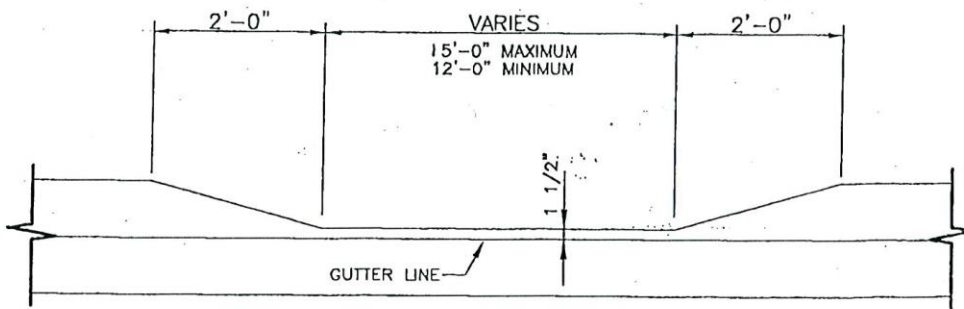

DEPRESSED CURB GUTTER



**SCHOOR DEPALMA**

Engineers and Consultants

1555 BUSTARD ROAD, SUITE 501  
P.O. BOX 304  
KULPSVILLE, PA 19443  
TEL (215)361-6050  
FAX (215)361-6160

MANALAPAN • ARMONK • ATLANTIC CITY • BRICK • CLINTON • EXTON • KULPSVILLE  
PARSIPPANY • PHILADELPHIA • PHILLIPSBURG • STAFFORD • VOORHEES

3

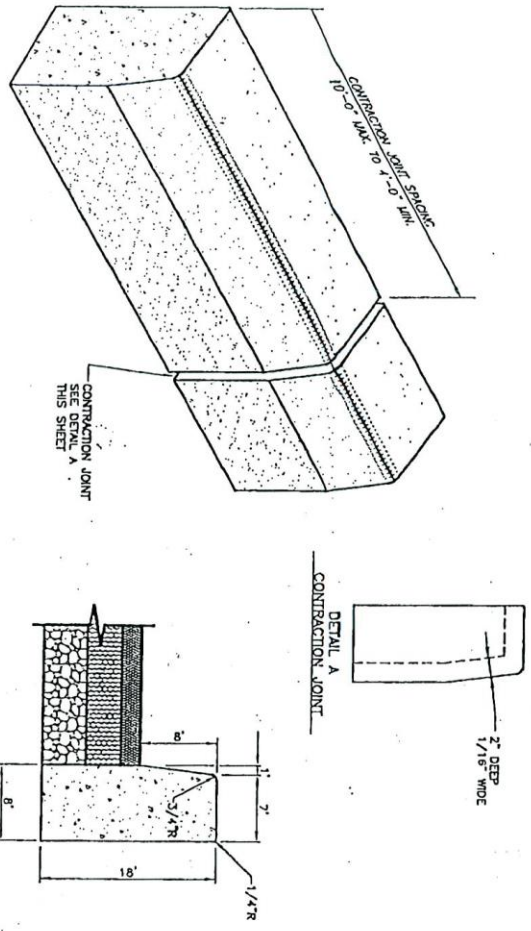

- CONCRETE CURBING NOTES :**
1. CONCRETE SHALL BE FORDOR CLASS 'X'.
  2. THREE-QUARTER INCH (3/4") EXPANSION MATERIAL JOINTS SHALL BE PLACED AT MINIMUM INTERVALS OF 7 FEET.
  3. MAXIMUM CONTRACTION JOINT SPACING SHALL BE (10) FEET. MINIMUM CONTRACTION JOINT SPACING SHALL BE FOUR (4) FEET.
  4. FLEXIBLE FORMS SHALL BE REQUIRED FOR ALL CURB RADI WITH A RADIUS OF LESS THAN 120 FEET.

**PLAIN CEMENT CONCRETE CURB DETAIL**  
N.T.S.



**SCHOOR DEPALMA**  
Engineers and Consultants

1555 BUSTARD ROAD, SUITE 501  
P.O. BOX 304  
KULPSVILLE, PA 19443  
TEL (215)361-6050  
FAX (215)361-6160

MANALAPAN • ARMONK • ATLANTIC CITY • BRICK • CLINTON • EXTON • KULPSVILLE  
PARSIPPANY • PHILADELPHIA • PHILLIPSBURG • STAFFORD • VOORHEES